

MOBILE DEVICE CHARGING AND STORAGE SOLUTIONS

BUYER'S GUIDE

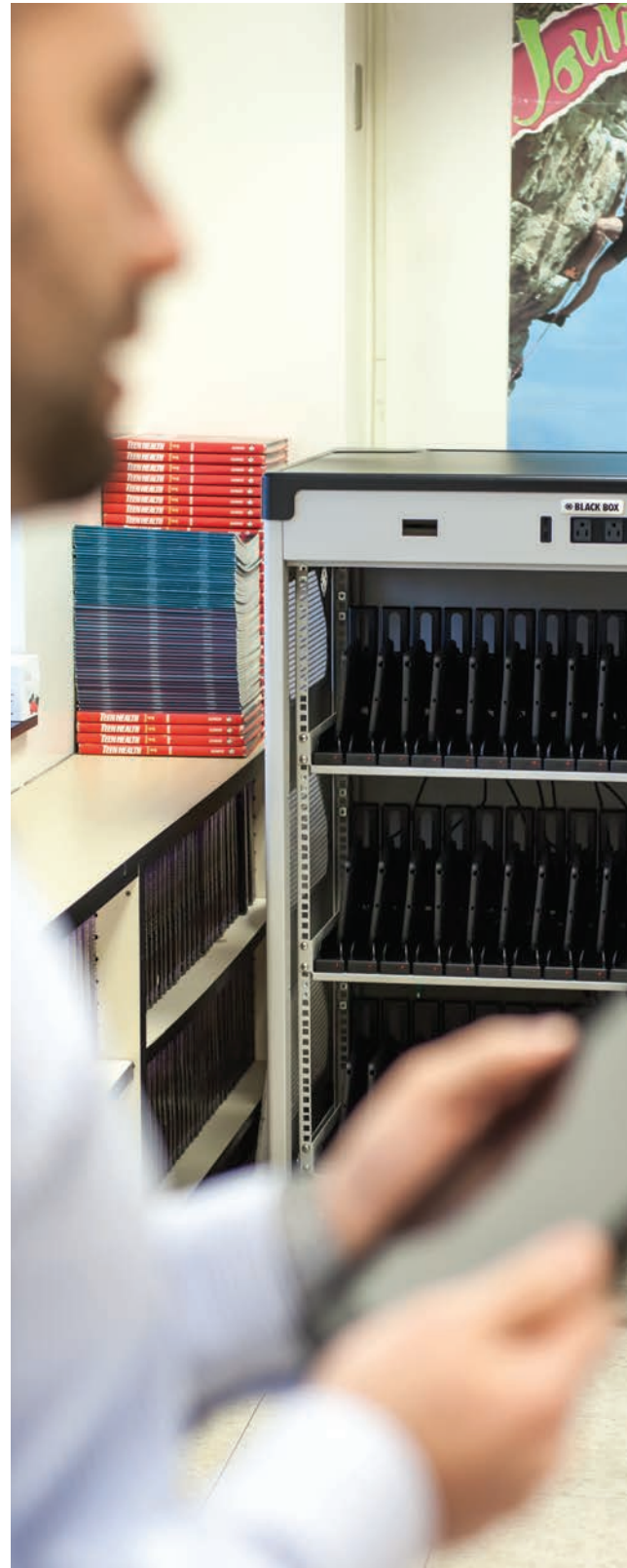



WHY BLACK BOX?

Black Box's award-winning charging cart solutions help you expand and enhance education technology in your school with advanced features that lead the market in affordability, security, safety and time-savings. Whether you're a teacher, IT tech or administrator, Black Box Charging and Storage Solutions make your life easier. You'll find all you need for charging, storing, syncing and transporting Chromebooks®, laptops, iPads®, tablets and other mobile devices.

WHY BLACK BOX IS BETTER

- Unbeatable value
- In stock, ready to ship
- Rugged steel construction
- Rapid wiring system
- Safety first design
- Multiple charging options
- Lifetime warranty, three years on electronics

NEED HELP SELECTING THE BEST MODEL FOR YOUR NEEDS AND BUDGET? CALL, CHAT, EMAIL OR USE OUR ONLINE SELECTOR.

EXPLORE THE OPTIONS AT BLACKBOX.COM/BUILDMYCART

CHARGING OPTIONS

Basic Charging—includes one PDU for every shelf that plugs into a distribution box. The distribution box plugs in the wall.

Standard Charging—cut charging time by 25% with our new standard timer. It also prevents breakers from tripping and damaging devices. Choose which groups of devices to charge and how long to charge them, from 5 to 60 minutes.

Intelligent Charging—detects and charges groups of low-battery devices first while reducing energy consumption. Power cycling prevents circuit breakers from tripping and damaging devices.

Sync and Charge—mobile devices for data transfers and software updates.

GDS® Wireless Charging System—eliminates power cords, making distributing devices during class faster. IntelliSkin™ cases protect devices. Individual LEDs indicate charging status.

CHARGING TYPE	BASIC CARTS	STANDARD CARTS	DELUXE CARTS	WALLMOUNT CHARGING LOCKERS
Basic	N/A	•	N/A	•
Standard	N/A	•	•	N/A
Intelligent	N/A	•	•	N/A
GDS® Wireless Charging	N/A	N/A	•	•
Sync and Charge	N/A	N/A	•	•

MOBILE CHARGING CARTS



BASIC CHARGING CARTS

- 30 to 36 devices
- Basic charging system
- 3" heavy-duty casters
- No front cable management (must upgrade to Standard)
- Keyed or hasped (optional)

\$

BASIC CHARGING CARTS - PG 5



STANDARD CHARGING CARTS

- 30 to 36 devices
- 5" heavy-duty casters
- Basic charging (included)
- Standard charging (optional)
- Intelligent charging (optional)
- Keyed or hasped (optional)
- Front cable management (optional)
- External power (optional)

\$\$

STANDARD CHARGING CARTS - PG 6



DELUXE CHARGING CARTS

- 30 to 48 devices
- 19/23" universal IT racking
- 5" heavy-duty casters
- Standard charging (base)
- Standard front and rear cable management
- Intelligent charging (optional)
- Wireless charging (optional)
- Sync and charge (optional)
- Keyed or hasped (optional)
- External power (optional)
- Basket distribution (optional)
- Sliding front door (optional)

\$\$\$

DELUXE CHARGING CARTS - PG 8

WALLMOUNT, MODULAR AND MASS CHARGING STORAGE



WALLMOUNT CHARGING LOCKERS

- 9, 10 and 12 device options
- Multiple configurations
- Wireless charging (optional)
- Sync and charge (optional)
- Keyed or hasped (optional)

\$

WALLMOUNT CHARGING LOCKERS - PG 10



MODULAR CHARGING LOCKERS

- 10, 20, 30 or 40 devices
- Modular system
- One locker holds 10 devices
- Rear cable management
- Up to four lockers can be stacked
- 19" universal IT racking
- Front cable management (optional)
- Podium work top (optional)
- 3" casters (optional)
- Tablet syncing/charging (optional)

\$

MODULAR CHARGING LOCKERS - PG 11



MASS CHARGING CABINETS

- 60 to 96 devices
- Tablets, Chromebooks or laptops
- Fully welded frame
- Can hold up to 2,200 pounds
- Intelligent charging (optional)
- Sync modules (optional)
- Power-controlled charging (optional)
- PVC-coated shelf dividers (optional)
- Padded shelf liners (optional)
- Front cable management bars (optional)

\$\$\$

MASS CHARGING CABINETS - PG 11





RAPID WIRING SYSTEM

HOOK AND LOOP MANAGERS HOLD POWER BRICKS



BEST-IN-CLASS MOBILE DEVICE STORAGE AND CHARGING SOLUTIONS

STANDARD OPTIONS

- Ruggedized steel construction
- Welded frame
- Small footprint
- Basic charging system
- Rapid wiring systems
- Safety-first design
- Lifetime warranty, three years on electronics
- Quick-release door system for easy access
- Easy-glide, heavy-duty casters

OPTIONAL FEATURES

- Advanced, intelligent, sync and wireless charging
- Hasp lock
- Rubberized dividers
- Protective shelf matting
- Exterior power and USB outlets
- Exterior LCD panels
- Basket distribution system



GDS® WIRELESS CHARGING SYSTEM



INTELLISKIN CASE

BASIC CHARGING CARTS

Top of the line construction with bottom line pricing

- Holds 30 to 36 devices
- Dimensions: 21"W x 22"D x 42"H
- 2-point locking
- Models available with either key lock or hasp lock
- Heavy-duty 3" casters provide unrestricted movement with controlled steering
- Carts include three 12-outlet power distribution units (PDUs) with 36 total outlets
- Compact carts fit in small spaces
- Three fixed 10-slot or 12-slot shelves
- Gray color, powder-coat finish
- Fully welded box frame, riveted and bolted panels
- One illuminated On/Off switch on each PDU (three total)
- Ships assembled
- UL60950 Approved; UL 1678 - Tip Test Compliant; CE, RoHS2
- Lifetime warranty, three years on electronics

LEARN MORE AT BLACKBOX.COM/CARTS

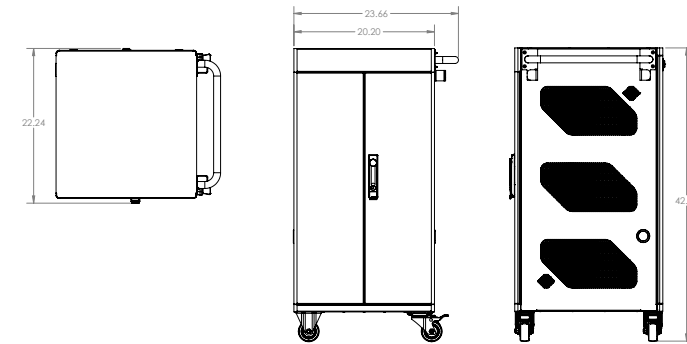

STANDARD FEATURES



OPTIONAL FEATURE



SELECTION GUIDE

DEVICE COUNT	CHARGING SYSTEM	DOOR TYPE	MAX. DEVICE SIZE (H X W X D)	LOCK	CATALOG #
30	Basic	Hinged	10.5" x 1.59" x 14.5"	Keyed	VLC30SK-HD
30	Basic	Hinged	10.5" x 1.59" x 14.5"	Hasped	VLC30SK-HD-HASP
36	Basic	Hinged	10.5" x 1.3" x 14.5"	Keyed	VLC36SK-HD-R2
36	Basic	Hinged	10.5" x 1.3" x 14.5"	Hasped	VLC36SK-HD-HASP



STANDARD CHARGING CARTS

Cut charging time by at least 25%

- Holds 30 or 36 devices
- Dimensions: 21"W x 22" x 44"H
- 5" Heavy-duty casters (2 locking and swiveling)
- 2-point locking with keyed or hasped options
- Feature rounded edges, no pinch points, no ledges and locking wheels for maximum safety
- 100% steel with fully welded steel frames
- Carts are rigorously tested to hold more than two times (minimum) the combined weight of all devices
- Rapid wiring system cable management
- Gray color, powder-coat finish
- Ships assembled
- UL60950 Approved; UL 1678 - Tip Test Compliant; CE, RoHS2
- Front cable management (optional)
- External power AC and USB outlets (optional)
- Standard charging (optional)
- Intelligent charging (optional)
- Lifetime warranty, three years on electronics

LEARN MORE AT BLACKBOX.COM/CARTS



STANDARD FEATURES

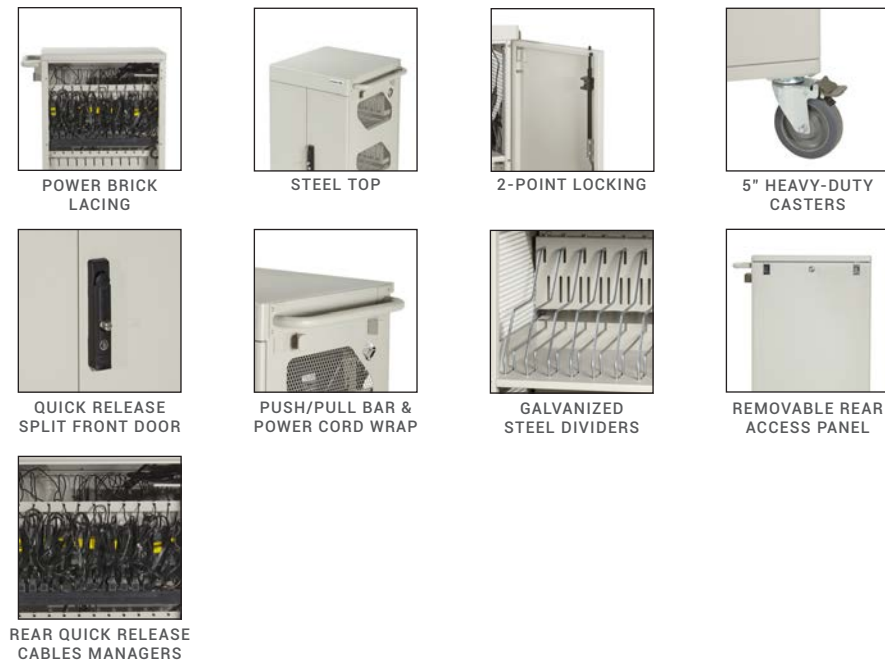

OPTIONAL FEATURES

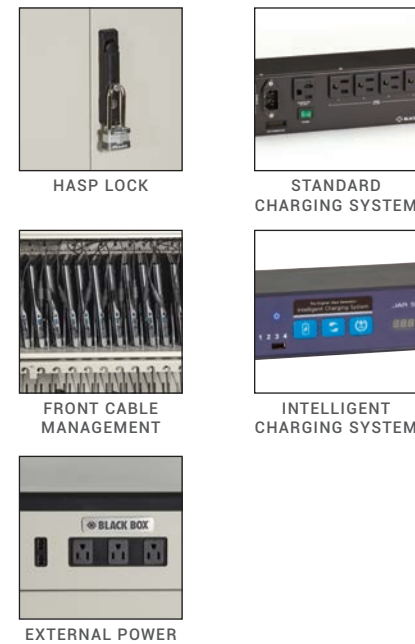

SELECTION GUIDE

DEVICE COUNT	CHARGING SYSTEM	DOOR TYPE	MAX. DEVICE SIZE (H X W X D)	FRONT CABLE MANAGEMENT	LOCK	EXTERNAL POWER	CATALOG #
30	Standard	Hinged	10.5" x 1.59" x 14.5"	No	Keyed	No	LCC30H-AT-R2
30	Standard	Hinged	10.5" x 1.59" x 14.5"	No	Keyed	Yes	LCC30H-ATP
30	Standard	Hinged	10.5" x 1.59" x 14.5"	No	Hasped	No	LCC30H-AT-HASP-R2
30	Standard	Hinged	10.5" x 1.59" x 14.5"	No	Hasped	Yes	LCC30H-ATP-HASP
30	Standard	Hinged	10.5" x 1.59" x 14.5"	Yes	Keyed	No	LCC30H-ACT-R2
30	Standard	Hinged	10.5" x 1.59" x 14.5"	Yes	Keyed	Yes	LCC30H-ACTP
30	Standard	Hinged	10.5" x 1.59" x 14.5"	Yes	Hasped	No	LCC30H-ACT-HASP
30	Standard	Hinged	10.5" x 1.59" x 14.5"	Yes	Hasped	Yes	LCC30H-ACTP-HASP
30	Basic	Hinged	10.5" x 1.59" x 14.5"	No	Keyed	No	LCC30H-A-R2
30	Basic	Hinged	10.5" x 1.59" x 14.5"	No	Keyed	Yes	LCC30H-AP
30	Basic	Hinged	10.5" x 1.59" x 14.5"	No	Hasped	No	LCC30H-A-HASP-R2
30	Basic	Hinged	10.5" x 1.59" x 14.5"	No	Hasped	Yes	LCC30H-AP-HASP
30	Basic	Hinged	10.5" x 1.59" x 14.5"	Yes	Keyed	No	LCC30H-AC-R2
30	Basic	Hinged	10.5" x 1.59" x 14.5"	Yes	Keyed	Yes	LCC30H-ACP
30	Basic	Hinged	10.5" x 1.59" x 14.5"	Yes	Hasped	No	LCC30H-AC-HASP-R2
30	Basic	Hinged	10.5" x 1.59" x 14.5"	Yes	Hasped	Yes	LCC30H-ACP-HASP
30	Intelligent	Hinged	10.5" x 1.59" x 14.5"	No	Keyed	No	LIC30H-A
30	Intelligent	Hinged	10.5" x 1.59" x 14.5"	No	Keyed	Yes	LIC30H-AP
30	Intelligent	Hinged	10.5" x 1.59" x 14.5"	No	Hasped	No	LIC30H-A-HASP
30	Intelligent	Hinged	10.5" x 1.59" x 14.5"	No	Hasped	Yes	LIC30H-AP-HASP
30	Intelligent	Hinged	10.5" x 1.59" x 14.5"	Yes	Keyed	No	LIC30H-AC
30	Intelligent	Hinged	10.5" x 1.59" x 14.5"	Yes	Keyed	Yes	LIC30H-ACP
30	Intelligent	Hinged	10.5" x 1.59" x 14.5"	Yes	Hasped	No	LIC30H-AC-HASP
30	Intelligent	Hinged	10.5" x 1.59" x 14.5"	Yes	Hasped	Yes	LIC30H-ACP-HASP
36	Standard	Hinged	10.5" x 1.3" x 14.5"	No	Keyed	No	LCC36H-AT-R2
36	Standard	Hinged	10.5" x 1.3" x 14.5"	No	Keyed	Yes	LCC36H-ATP
36	Standard	Hinged	10.5" x 1.3" x 14.5"	No	Hasped	No	LCC36H-AT-HASP
36	Standard	Hinged	10.5" x 1.3" x 14.5"	No	Hasped	Yes	LCC36H-ATP-HASP
36	Standard	Hinged	10.5" x 1.3" x 14.5"	Yes	Keyed	No	LCC36H-ACT-R2
36	Standard	Hinged	10.5" x 1.3" x 14.5"	Yes	Keyed	Yes	LCC36H-ACTP
36	Standard	Hinged	10.5" x 1.3" x 14.5"	Yes	Hasped	No	LCC36H-ACT-HASP
36	Standard	Hinged	10.5" x 1.3" x 14.5"	Yes	Hasped	Yes	LCC36H-ACTP-HASP
36	Basic	Hinged	10.5" x 1.3" x 14.5"	No	Keyed	No	LCC36H-A-R2
36	Basic	Hinged	10.5" x 1.3" x 14.5"	No	Keyed	Yes	LCC36H-AP
36	Basic	Hinged	10.5" x 1.3" x 14.5"	No	Hasped	No	LCC36H-A-HASP
36	Basic	Hinged	10.5" x 1.3" x 14.5"	No	Hasped	Yes	LCC36H-AP-HASP
36	Basic	Hinged	10.5" x 1.3" x 14.5"	Yes	Keyed	No	LCC36H-AC-R2
36	Basic	Hinged	10.5" x 1.3" x 14.5"	Yes	Keyed	Yes	LCC36H-ACP
36	Basic	Hinged	10.5" x 1.3" x 14.5"	Yes	Hasped	No	LCC36H-AC-HASP
36	Basic	Hinged	10.5" x 1.3" x 14.5"	Yes	Hasped	Yes	LCC36H-ACP-HASP
36	Intelligent	Hinged	10.5" x 1.3" x 14.5"	No	Keyed	No	LIC36H-A
36	Intelligent	Hinged	10.5" x 1.3" x 14.5"	No	Keyed	Yes	LIC36H-AP
36	Intelligent	Hinged	10.5" x 1.3" x 14.5"	No	Hasped	No	LIC36H-A-HASP
36	Intelligent	Hinged	10.5" x 1.3" x 14.5"	No	Hasped	Yes	LIC36H-AP-HASP
36	Intelligent	Hinged	10.5" x 1.3" x 14.5"	Yes	Keyed	No	LIC36H-AC
36	Intelligent	Hinged	10.5" x 1.3" x 14.5"	Yes	Keyed	Yes	LIC36H-ACP
36	Intelligent	Hinged	10.5" x 1.3" x 14.5"	Yes	Hasped	No	LIC36H-AC-HASP
36	Intelligent	Hinged	10.5" x 1.3" x 14.5"	Yes	Hasped	Yes	LIC36H-ACP-HASP



DELUXE CHARGING CARTS

These Best-in-Show, award-winning Deluxe Charging Carts give you many options for storing and charging Chromebooks®, laptops, tablets and other mobile devices

- One cart holds from 30 to 42 devices
- With a Basket Distribution System, the cart can hold up to 48 devices
- Feature round edges, corner bumpers, no pinch points, no ledges and locking wheels for maximum safety
- Keyed or hasped locking options
- Include front and rear quick-release cable managers for up to 50% faster device distribution
- Standard charging with NEMA 5-15P power cord
- Distribute devices up to 50% faster with basket distribution
- Store more devices in a small footprint, saving classroom space
- Wire carts in less than 30 minutes
- Charge devices up to 25% faster with your choice of cart charging options
- Adjustable shelving
- UL60950 Approved; UL 1678 - Tip Test Compliant; CE, RoHS2
- External charging indication (optional)
- Intelligent charging (optional)
- GDS® Wireless charging for tablets (optional)
- Syncing and charging for tablets (optional)
- Shelf and divider device protection (optional)
- Lifetime warranty, three years on electronics

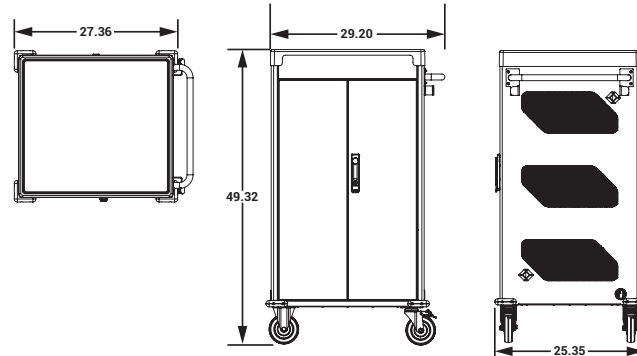

LEARN MORE AT BLACKBOX.COM/CARTS

STANDARD FEATURES



POWER BRICK LACING



MOLDED PLASTIC TOP



2-POINT LOCKING



5" HEAVY-DUTY CASTERS



QUICK RELEASE SPLIT FRONT DOOR



PUSH/PULL BAR & POWER CORD WRAP



RACKMOUNTED SHELF



REMOVABLE REAR ACCESS PANEL



CORNER BUMPERS



CART TIMER UNIT (CARTTIMER2)

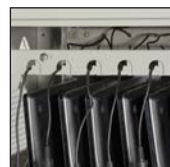

QUICK RELEASE CABLE MANAGERS



19" AND 23" EIA-310 RACK-MOUNT RAILS

OPTIONAL FEATURES



HASP LOCK



INTELLIGENT CHARGING SYSTEM



DRAWER



BASKET DISTRIBUTION



EXTERNAL POWER



SLIDING FRONT DOOR

SELECTION GUIDE | FOR DEVICES UP TO 13" DEEP

DEVICE COUNT	CHARGING SYSTEM	DOOR TYPE	MAX. DEVICE SIZE (H X W X D)	KEYED WITHOUT EXTERNAL POWER	KEYED WITH EXTERNAL POWER	HASPED WITHOUT EXTERNAL POWER	HASPED WITH EXTERNAL POWER
30	Standard	Hinged	10.62" x 1.36" x 13"	UCCSM-10-30H-R2	UCCSM-10-30HP-R2	UCCSM-10-30H-HASP-R2	UCCSM-10-30HP-HASP
30	Standard	Sliding	10.62" x 1.36" x 13"	UCCSM-10-30T-R2	UCCSM-10-30TP-R2	UCCSM-10-30T-HASP-R2	UCCSM-10-30TP-HASP
30	Intelligent	Hinged	10.62" x 1.36" x 13"	UICSM-10-30H	UICSM-10-30HP	UICSM-10-30H-HASP	UICSM-10-30HP-HASP
30	Intelligent	Sliding	10.62" x 1.36" x 13"	UICSM-10-30T	UICSM-10-30TP	UICSM-10-30T-HASP	UICSM-10-30TP-HASP
36	Standard	Hinged	10.62" x 1.1" x 15"	UCCSM-12-36H-R2	UCCSM-12-36HP	UCCSM-12-36H-HASP	UCCSM-12-36HP-HASP
36	Standard	Sliding	10.62" x 1.1" x 15"	UCCSM-12-36T-R2	UCCSM-12-36TP	UCCSM-12-36T-HASP	UCCSM-12-36TP-HASP
36	Intelligent	Hinged	10.62" x 1.1" x 15"	UICSM-12-36H	UICSM-12-36HP	UICSM-12-36H-HASP	UICSM-12-36HP-HASP
36	Intelligent	Sliding	10.62" x 1.1" x 15"	UICSM-12-36T	UICSM-12-36TP	UICSM-12-36T-HASP	UICSM-12-36TP-HASP
42	Standard	Hinged	10.62" x 0.91" x 13"	UCCSM-14-42H-R2	UCCSM-14-42HP	UCCSM-14-42H-HASP	UCCSM-14-42HP-HASP
42	Standard	Sliding	10.62" x 0.91" x 13"	UCCSM-14-42T-R2	UCCSM-14-42TP	UCCSM-14-42T-HASP	UCCSM-14-42TP-HASP
42	Intelligent	Hinged	10.62" x 0.91" x 13"	UICSM-14-42H	UICSM-14-42HP	UICSM-14-42H-HASP	UICSM-14-42HP-HASP
42	Intelligent	Sliding	10.62" x 0.91" x 13"	UICSM-14-42T	UICSM-14-42TP	UICSM-14-42T-HASP	UICSM-14-42TP-HASP

SELECTION GUIDE | FOR DEVICES UP TO 17" DEEP

DEVICE COUNT	CHARGING SYSTEM	DOOR TYPE	MAX. DEVICE SIZE (H X W X D)	KEYED WITHOUT EXTERNAL POWER	KEYED WITH EXTERNAL POWER	HASPED WITHOUT EXTERNAL POWER	HASPED WITH EXTERNAL POWER
36	Standard	Hinged	11.75" x 1.5" x 17"	UCCSL-12-36H	UCCSL-12-36HP	UCCSL-12-36H-HASP	UCCSL-12-36HP-HASP
36	Standard	Sliding	11.75" x 1.5" x 17"	UCCSL-12-36T	UCCSL-12-36TP	UCCSL-12-36T-HASP	UCCSL-12-36TP-HASP
36	Intelligent	Hinged	11.75" x 1.5" x 17"	UICSL-12-36H	UICSL-12-36HP	UICSL-12-36H-HASP	UICSL-12-36HP-HASP
36	Intelligent	Sliding	11.75" x 1.5" x 17"	UICSL-12-36T	UICSL-12-36TP	UICSL-12-36T-HASP	UICSL-12-36TP-HASP
42	Standard	Hinged	11.75" x 1.25" x 17"	UCCSL-14-42H	UCCSL-14-42HP	UCCSL-14-42H-HASP	UCCSL-14-42HP-HASP
42	Standard	Sliding	11.75" x 1.25" x 17"	UCCSL-14-42T	UCCSL-14-42TP	UCCSL-14-42T-HASP	UCCSL-14-42TP-HASP
42	Intelligent	Hinged	11.75" x 1.25" x 17"	UICSL-14-42H	UICSL-14-42HP	UICSL-14-42H-HASP	UICSL-14-42HP-HASP
42	Intelligent	Sliding	11.75" x 1.25" x 17"	UICSL-14-42T	UICSL-14-42TP	UICSL-14-42T-HASP	UICSL-14-42TP-HASP

SELECTION GUIDE | FOR DEVICES UP TO 10" DEEP

DEVICE COUNT	CHARGING SYSTEM	DOOR TYPE	MAX. DEVICE SIZE (H X W X D)	KEYED WITHOUT EXTERNAL POWER	KEYED WITH EXTERNAL POWER	HASPED WITHOUT EXTERNAL POWER	HASPED WITH EXTERNAL POWER
30	Standard	Hinged	10.62" x 1.4" x 10"	UCCSS-10-30H	UCCSS-10-30HP	UCCSS-10-30H-HASP	UCCSS-10-30HP-HASP
30	Standard	Sliding	10.62" x 1.4" x 10"	UCCSS-10-30T	UCCSS-10-30TP	UCCSS-10-30T-HASP	UCCSS-10-30TP-HASP
30	Intelligent	Hinged	10.62" x 1.4" x 10"	UICSS-10-30H	UICSS-10-30HP	UICSS-10-30H-HASP	UICSS-10-30HP-HASP
30	Intelligent	Sliding	10.62" x 1.4" x 10"	UICSS-10-30T	UICSS-10-30TP	UICSS-10-30T-HASP	UICSS-10-30TP-HASP
30	Syncing	Hinged	10.62" x 1.4" x 10"	UCCSS-10-30H-S	UCCSS-10-30HP-S	UCCSS-10-30H-S-HASP	UCCSS-10-30HP-S-HASP
30	Syncing	Sliding	10.62" x 1.4" x 10"	UCCSS-10-30T-S	UCCSS-10-30TP-S	UCCSS-10-30T-S-HASP	UCCSS-10-30TP-S-HASP
33	Wireless Tablet	Hinged	Tablets with IntelliSkin™ Cases	UCCSW-11-33H	UCCSW-11-33HP	UCCSW-11-33H-HASP	UCCSW-11-33HP-HASP
33	Wireless Tablet	Sliding	Tablets with IntelliSkin™ Cases	UCCSW-11-33T	UCCSW-11-33TP	UCCSW-11-33T-HASP	UCCSW-11-33TP-HASP
36	Standard	Hinged	10.62" x 1.15" x 10"	UCCSS-12-36H-R2	UCCSS-12-36HP	UCCSS-12-36H-HASP	UCCSS-12-36HP-HASP
36	Standard	Sliding	10.62" x 1.15" x 10"	UCCSS-12-36T-R2	UCCSS-12-36TP	UCCSS-12-36T-HASP	UCCSS-12-36TP-HASP
36	Intelligent	Hinged	10.62" x 1.15" x 10"	UICSS-12-36H	UICSS-12-36HP	UICSS-12-36H-HASP	UICSS-12-36HP-HASP
36	Intelligent	Sliding	10.62" x 1.15" x 10"	UICSS-12-36T	UICSS-12-36TP	UICSS-12-36T-HASP	UICSS-12-36TP-HASP
36	Syncing	Hinged	10.62" x 1.15" x 10"	UCCSS-12-36H-S	UCCSS-12-36HP-S	UCCSS-12-36H-S-HASP	UCCSS-12-36HP-S-HASP
36	Syncing	Sliding	10.62" x 1.15" x 10"	UCCSS-12-36T-S	UCCSS-12-36TP-S	UCCSS-12-36T-S-HASP	UCCSS-12-36TP-S-HASP

SELECTION GUIDE | WITH BASKET DISTRIBUTION SYSTEM

DEVICE COUNT	CHARGING SYSTEM	DOOR TYPE	MAX. DEVICE SIZE (H X W X D)	KEYED WITHOUT EXTERNAL POWER	KEYED WITH EXTERNAL POWER	HASPED WITHOUT EXTERNAL POWER	HASPED WITH EXTERNAL POWER
48	Standard	Hinged	11.05" x 1.1" x 15"	UCCSB-BIN1-48H	UCCSB-BIN1-48HP	UCCSB-BIN1-48H-HASP	UCCSB-BIN1-48HP-HASP
48	Intelligent	Hinged	11.05" x 1.1" x 15"	UICSB-BIN1-48H	UICSB-BIN1-48HP	UICSB-BIN1-48H-HASP	UICSB-BIN1-48HP-HASP



WALLMOUNT CHARGING LOCKERS

When you need to conserve real estate

- Holds 9, 10 or 12 devices based on model
- Stackable: front to back, side to side or top to bottom
- Dimensions: 21"W x 16"D x 17"H
- Slot size, 10 devices: 1.48"W x 12.5"H x 13.9"D
- Slot size, 12 devices: 1.20"W x 12.5"H x 13.9"D
- Desk and wallmountable
- 2-point locking with keyed or hasped locking option
- Front power management drawer to hold power bricks
- Integrated front cable management
- 19" IT rack rails, 7U with 15" internal depth
- Wireless tablet charging to eliminate power cords (optional)
- Sync and charge (optional)

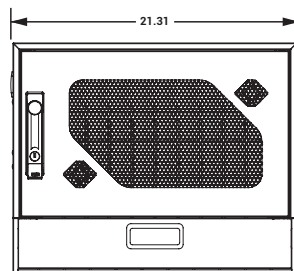

FRONT

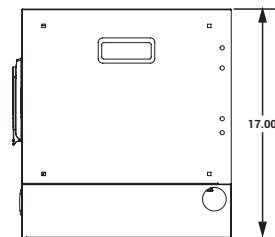

SIDE

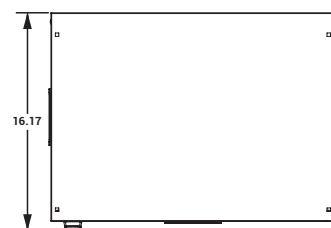

TOP

Whether you're a teacher, IT tech or administrator, Black Box Wallmount Charging Lockers are engineered to save your floor space—and your budget. Ideal for smaller classrooms, offices and training environments that are short on space. The lockers hold 9, 10 or 12 devices based on model. They also give you the versatility to mount multiple lockers together for more storage options. Adjustable 19" rackmount rails enable you to mount other IT equipment, too. Plus, the 100% steel lockers hold up to 150 pounds and are guaranteed for life.

LEARN MORE AT BLACKBOX.COM/WALLMOUNT

SELECTION GUIDE

SHELF COUNT	CHARGING	SHELF TYPE	LOCKING DRAWER	LOCK	CATALOG #
10	PDU	Divider	—	Keyed	UWL-10KD
10	PDU	Divider	•	Keyed	UWL-10KLD
10	PDU	Divider	—	Hasped	UWL-10PD
10	PDU	Divider	•	Hasped	UWL-10PLD
12	PDU	Divider	—	Keyed	UWL-12KD
12	PDU	Divider	•	Keyed	UWL-12KLD
12	PDU	Divider	—	Hasped	UWL-12PD
12	PDU	Divider	•	Hasped	UWL-12PLD
9	Wireless Tablet	Dock	—	Keyed	UWLW-9KD
9	Wireless Tablet	Dock	—	Hasped	UWLW-9PD
10	USB Syncing	Divider	—	Keyed	UWLS-10KD
10	USB Syncing	Divider	•	Keyed	UWLS-10KLD
10	USB Syncing	Divider	—	Hasped	UWLS-10PD
10	USB Syncing	Divider	•	Hasped	UWLS-10PLD
12	USB Syncing	Divider	—	Keyed	UWLS-12KD
12	USB Syncing	Divider	•	Keyed	UWLS-12KLD
12	USB Syncing	Divider	—	Hasped	UWLS-12PD
12	USB Syncing	Divider	•	Hasped	UWLS-12PLD



MODULAR CHARGING LOCKERS

Stackable and configurable, start small and grow later

- 10, 20, 30 or 40 devices
- Modular system
- One locker holds 10 devices
- Slot size: 1.36"W x 10"H x 15"D
- Up to four lockers can be stacked
- 19" universal IT racking
- Front cable management (optional)
- Rear cable management/front (optional)
- Podium work top (optional)
- 3" casters to add mobility (optional)
- Syncing/wireless charging (optional)

LEARN MORE AT BLACKBOX.COM/LOCKER

CATALOG # DESCRIPTION

IPAD®, CHROMEBOOK® AND TABLET LOCKERS

UD10KP	10 Devices
UD10KP-LD	10 Devices with Drawer and Laminate Top
UD10KP-C	10 Devices with Drawer, Laminate Top and Casters
UD20KP	20 Devices
UD20KP-LD	20 Devices with Drawer and Laminate Top
UD20KP-C	20 Devices with Drawer, Laminate Top and Casters
UD30KP	30 Devices
UD30KP-LD	30 Devices with Drawer and Laminate Top
UD40KP	40 Devices

ACCESSORIES

UDDRAWER	Universal Locker Drawer
UDCASTER	Universal Locker Casters
UDLAMINATE	Universal Locker Laminate



MASS CHARGING CABINETS

Get the most capacity in the smallest footprint

- 60 to 96 devices
- Tablets, Chromebooks or laptops
- Fully welded frame
- Can hold up to 2,200 pounds
- Intelligent charging (optional)
- Sync modules (optional)
- Power-controlled charging (optional)
- PVC-coated shelf dividers (optional)
- Padded shelf liners (optional)
- Front cable management bars (optional)

LEARN MORE AT BLACKBOX.COM/MASSSTORAGE

CATALOG # DESCRIPTION

FOR CHROMEBOOK® COMPUTERS OR LAPTOPS

MSC-60-CCN	60 Devices with Cable Management
MSC-60-CNN	60 Devices with No Cable Management
MSC-72-CCN	72 Devices with Cable Management
MSC-72-CNN	72 Devices with No Cable Management
UCCDIVIDER-ML	Rubber Shelf Divider for MSC-60 and MSC-72 Series
UCCLINER-M-12	Padded Shelf Liner for MSC-60 and MSC-72 Series

FOR TABLETS

MSC-84-TCN	84 Devices with Cable Management
MSC-84-TNN	84 Devices with No Cable Management
MSC-96-TCN	96 Devices with Cable Management
MSC-96-TNN	96 Devices with No Cable Management
UCCDIVIDER-S	Rubber Shelf Divider for MSC-84 and MSC-96 Series
UCCLINER-S-12	Padded Shelf Liner for MSC-84 and MSC-96 Series
UCCSYNC15	15-Unit Cambrionix Syncing Module
UCCSYNC15-P	Syncing Module Power Supply
SMMB	Syncing Module Mounting Bracket
UCCPC	12-ft. (3.6-m) Power Cord



CHROMEBOOK CARTS BUYER'S GUIDE

Keep your Chromebooks organized and safely stored away with these configurable carts. You can fit anywhere from 30 to 48 devices in a single cart. Also, choose between good, better and the best models available depending on your device dimensions. Use the selection guide below to help you choose the right cart that fits your Chromebook storage needs.



SELECTION GUIDE | TOP SELLING CHROMEBOOKS

MFG	PART NO.	DEVICE DIMENSIONS	DEVICES / CART							
			30	36	30	36	30	36	42	48
			GOOD		BETTER		BEST			
ACER	C720 11 4GB 16GB TOUCH CHROME	11.3" x 8" x 0.8"	VLC30SK-HD	VLC36SK-HD-R2	LCC30H-ACT-R2	LCC36H-ACT-R2	UCCSM-10-30H-R2	UCCSM-12-36H-R2	UCCSM-14-42H-R2	UCCSB-BIN1-48H
ACER	C738 11 4GB 16GB TOUCH CHROME	11.6" x 8" X 0.8"	VLC30SK-HD	VLC36SK-HD-R2	LCC30H-ACT-R2	LCC36H-ACT-R2	UCCSM-10-30H-R2	UCCSM-12-36H-R2	UCCSM-14-42H-R2	UCCSB-BIN1-48H
ACER	C740 11 3205U 4GB 16GB CHROME	11.3" x 8" x 0.8"	VLC30SK-HD	VLC36SK-HD-R2	LCC30H-ACT-R2	LCC36H-ACT-R2	UCCSM-10-30H-R2	UCCSM-12-36H-R2	UCCSM-14-42H-R2	UCCSB-BIN1-48H
ACER	C810 13 TEGRA 4GB 16GB CHROME	12.9" x 8.9" x 0.7"	VLC30SK-HD	VLC36SK-HD-R2	LCC30H-ACT-R2	LCC36H-ACT-R2	UCCSM-10-30H-R2	UCCSM-12-36H-R2	UCCSM-14-42H-R2	UCCSB-BIN1-48H
ASUS	C202 11 N3060 16GB 4GB CHROME	11.6" x 7.9" x 0.9"	VLC30SK-HD	VLC36SK-HD-R2	LCC30H-ACT-R2	LCC36H-ACT-R2	UCCSM-10-30H-R2	UCCSM-12-36H-R2	UCCSM-14-42H-R2	UCCSB-BIN1-48H
ASUS	FLIP C100 10 ROCKCHIP 16GB 4GB	10.4" x 7.2" x 0.6"	VLC30SK-HD	VLC36SK-HD-R2	LCC30H-ACT-R2	LCC36H-ACT-R2	UCCSM-10-30H-R2	UCCSM-12-36H-R2	UCCSM-14-42H-R2	UCCSB-BIN1-48H
DELL	CHROME 11 N2840 16GB 4GB BLK	11.7" x 8.5" x 0.8"	VLC30SK-HD	VLC36SK-HD-R2	LCC30H-ACT-R2	LCC36H-ACT-R2	UCCSM-10-30H-R2	UCCSM-12-36H-R2	UCCSM-14-42H-R2	UCCSB-BIN1-48H
HP	SB CHROME 11 G4 EE N2840 16GB 4GB	11.8" x 8.1" x 0.8"	VLC30SK-HD	VLC36SK-HD-R2	LCC30H-ACT-R2	LCC36H-ACT-R2	UCCSM-10-30H-R2	UCCSM-12-36H-R2	UCCSM-14-42H-R2	UCCSB-BIN1-48H
HP	SB CHROME 11 G4 N2840 16GB 2GB	11.8" x 8.1" x 0.8"	VLC30SK-HD	VLC36SK-HD-R2	LCC30H-ACT-R2	LCC36H-ACT-R2	UCCSM-10-30H-R2	UCCSM-12-36H-R2	UCCSM-14-42H-R2	UCCSB-BIN1-48H
HP	SB CHROME 11 G4 N2840 16GB 4GB	11.8" x 8.1" x 0.8"	VLC30SK-HD	VLC36SK-HD-R2	LCC30H-ACT-R2	LCC36H-ACT-R2	UCCSM-10-30H-R2	UCCSM-12-36H-R2	UCCSM-14-42H-R2	UCCSB-BIN1-48H
HP	SB CHROME 14 G4 N2840 16GB 4GB	13.5" x 9.4" x 0.7"	VLC30SK-HD	VLC36SK-HD-R2	LCC30H-ACT-R2	LCC36H-ACT-R2	UCCSM-10-30H-R2	UCCSM-12-36H-R2	UCCSM-14-42H-R2	UCCSB-BIN1-48H
LENOVO	11E N2940 16GB 4GB CHROME	11.8" x 8.5" x 0.9"	VLC30SK-HD	VLC36SK-HD-R2	LCC30H-ACT-R2	LCC36H-ACT-R2	UCCSM-10-30H-R2	UCCSM-12-36H-R2	UCCSM-14-42H-R2	UCCSB-BIN1-48H
LENOVO	11E YOGA N3150 16/4 TOUCH CHROME	11.8" x 8.3" x 0.9"	VLC30SK-HD	VLC36SK-HD-R2	LCC30H-ACT-R2	LCC36H-ACT-R2	UCCSM-10-30H-R2	UCCSM-12-36H-R2	UCCSM-14-42H-R2	UCCSB-BIN1-48H
LENOVO	N22 11 N3050 16GB 4GB CHROME	11.8" x 8.5" x 0.9"	VLC30SK-HD	VLC36SK-HD-R2	LCC30H-ACT-R2	LCC36H-ACT-R2	UCCSM-10-30H-R2	UCCSM-12-36H-R2	UCCSM-14-42H-R2	UCCSB-BIN1-48H
LENOVO	TS N21 11 N2840 16GB 4GB CHROME	11.8" x 8.5" x 0.9"	VLC30SK-HD	VLC36SK-HD-R2	LCC30H-ACT-R2	LCC36H-ACT-R2	UCCSM-10-30H-R2	UCCSM-12-36H-R2	UCCSM-14-42H-R2	UCCSB-BIN1-48H
SAMSUNG	CHROME 2 11.6 2GB/16GB INTEL CPS	11.4" x 8.1" x 0.7"	VLC30SK-HD	VLC36SK-HD-R2	LCC30H-ACT-R2	LCC36H-ACT-R2	UCCSM-10-30H-R2	UCCSM-12-36H-R2	UCCSM-14-42H-R2	UCCSB-BIN1-48H
SAMSUNG	CHROME 2 11.6 4GB/16GB INTEL	11.4" x 8.1" x 0.7"	VLC30SK-HD	VLC36SK-HD-R2	LCC30H-ACT-R2	LCC36H-ACT-R2	UCCSM-10-30H-R2	UCCSM-12-36H-R2	UCCSM-14-42H-R2	UCCSB-BIN1-48H
SAMSUNG	CHROME 3 11.6 2GB/16GB N3050 BLK	11.4" x 8" x 0.7"	VLC30SK-HD	VLC36SK-HD-R2	LCC30H-ACT-R2	LCC36H-ACT-R2	UCCSM-10-30H-R2	UCCSM-12-36H-R2	UCCSM-14-42H-R2	UCCSB-BIN1-48H
SAMSUNG	CHROME 3 11.6 4GB/16GB N3050 BLK	11.4" x 8" x 0.7"	VLC30SK-HD	VLC36SK-HD-R2	LCC30H-ACT-R2	LCC36H-ACT-R2	UCCSM-10-30H-R2	UCCSM-12-36H-R2	UCCSM-14-42H-R2	UCCSB-BIN1-48H



$$A^2 + B^2 = C^2$$

$$3^2 + 4^2 = 5^2$$

$$9 + 16 = 25$$





1.877.877.2269



BLACKBOX.COM