

Product Data Sheet

18- or 27-Device iPad®, Chromebook™, Tablet, and Laptop Cart, Single Frame with Medium Slots and Hinged or Sliding Door, and Intelligent Charging System

Benefits

- The “buy it once own it for life” flexible racking technology allows your cart to change as your devices change.
- The safety first design greatly helps reduce potential injuries or accidents.
- The rapid wiring system reduces the time to deploy by as much as 75%.
- Intelligent charging units reduce energy consumption and detect and charge low battery devices first.



Features

- Store, secure, transport, and charge any combination of up to 18 or 27 iPads, Chromebooks, laptops, or tablets.
- Three removable 18-slot shelves enable flexible configuration.
- Swap out the shelves for laptops, notebooks, tablets, and e-readers, or for other equipment and storage options.
- Single Carts hold more in a smaller footprint.
- A usable working surface serves as a podium or writing surface.
- The always-on internal user outlet keeps users safe from the potential danger of electric shock.
- Includes Intelligent Charging System.
- Includes durable all-steel chassis and locking doors for security.
- Vented panels and doors keep equipment cool.
- Cable management bars and power wraps maintain order.
- Optional drawers and shelves accommodate DVD players, printers, projectors, and other peripheral devices.
- Casters (5" heavy-duty) provide unrestricted and easy movement with controlled steering and functionality.
- Ships fully assembled.
- Users can access devices from the front of the cart, and IT administrators from the back.
- Push/pull handle on cart doubles as a power cord wrap.

Why Black Box

- Black Box is one of the leading providers of carts and lockers in the world. Founded in 1976, Black Box is publically traded and does more than \$1 billion in annual sales.
- Every cart includes our lifetime, no-questions-asked warranty (electronics three years). It covers just about everything and includes accidental damage. We don't hide behind limited liability warranties that cover very little.
- Black Box offers a wide selection of standard and custom cart solutions. Black Box has extensive production capacity and maintains large inventories for immediate shipments.
- Ruggedized, heavy-duty carts are guaranteed to last a lifetime. Black Box carts are the heaviest and most durable carts on the market.
- Our carts give you the best value and lowest lifetime cost based on life-use expectancy.

18- or 27-Device Cart with Intelligent Charging System Data Sheet

Features



Standard rack mounting allows greater flexibility.



UCCSM-12-36H has hinged door with handle.



Power brick lacing stores power bricks easily and neatly (medium- and large-shelf models only).



Durable push/pull bar and power cord wrap.



Rackmounted shelf with rolled stainless steel device slots that help prevent scratches.



Locking rear access panel.



Cable managers open easily for fast cable routing.



Laminate top provides extra working space.

Optional Features



Optional integrated pop-up power port for maximum safety.



Optional drawers and shelves available.

Standard Features



UCCSM18T-ILC or UCCSM27T-ILC "pinchless" sliding door saves space.



SDILCU4 Intelligent Charging System is easy to use—press one button to start charging.

Ordering Information

18- or 27-Device Chromebook and Laptop Cart, Single Frame with Medium Slots and Hinged Door
(UCCSM18H-ILC or UCCSM27H-ILC)



18- or 27-Device Chromebook and Laptop Cart, Single Frame with Medium Slots and Sliding Door
(UCCSM18T-ILC or UCCSM27T-ILC)



18- or 27-Device Cart with Intelligent Charging System Data Sheet

Technical Specifications

Approvals	UL® approved power strip and timers
Assembled	Yes
Cable Access	Side sections each have a 1.43" diameter hole
Color	Gray
Construction	16-gauge steel with vented sides
Device Capacity	(18) or (27) Chromebooks or Laptops
Locking	Key: Locking front door and rear access panel for easy cable management (keyed differently)
Slot Dimensions	UCCSM18T-ILC, UCCSM18H-ILC: Storage Slots: (18) total, (9) per shelf, (2) shelves, 13"H x 1.53"W x 15"D (33.02 x 3.89 x 38.1 cm); UCCSM27T-ILC, UCCSM27H-ILC: Storage Slots: (27) total, (9) per shelf, (3) shelves, 8.75"H x 1.53"W x 15"D (22.22 x 3.89 x 38.1 cm)
Power	Input: 110–120 VAC (6-foot attached power cord included), 50/60 Hz, Plug type: 5-15P, Outlet type: 5-15R; Outlet count: (24), via (2) 12-outlet power strips, 15-A maximum; On/Off switch: Yes
Charging System	(1) Intelligent Charging System (SDILCU4)
Dimensions	Cart: 44.27"H x 33.07"W x 25.35"D (112.4 x 83.99 x 64.39 cm); Shipping Carton: 48.5"H x 35"W x 32"D (123.19 x 88.9 x 81.28 cm)
Weight Capacity on Top Surface	150 lb. (68.2 kg), stationary
Warranty	Carts: Lifetime; Electronics: 3 years The Black Box Double Diamond Warranty is our no-questions-asked warranty that protects your Black Box carts and locker from manufacturer defects, accidental damages, liquid spills, and power surges.

Comparison Chart: iPad, Chromebook, Tablet, and Laptop Carts with Hinged or Sliding Doors

	UCCSM18T-ILC	UCCSM18H-ILC	UCCSM27T-ILC	UCCSM27H-ILC
Device capacity	18 Chromebooks, Laptops, Netbooks, or Tablets	18 Chromebooks, Laptops, Netbooks, or Tablets	27 Chromebooks, Laptops, Netbooks, or Tablets	27 Chromebooks, Laptops, Netbooks, or Tablets
Outlet strips	(2) 12-outlet power strips	(2) 12-outlet power strips	(3) 12-outlet power strips	(3) 12-outlet power strips
Casters (5" heavy-duty) included	Yes	Yes	Yes	Yes
Door Type	Sliding	Hinged	Sliding	Hinged
Laminate top included	Yes	Yes	Yes	Yes
Slot size	Height: 13" (33.02 cm); Width: 1.53" (3.89 cm); Depth: 15" (38.1 cm)	Height: 13" (33.02 cm); Width: 1.53" (3.89 cm); Depth: 15" (38.1 cm)	Height: 8.75" (22.22 cm); Width: 1.53" (3.89 cm); Depth: 15" (38.1 cm)	Height: 8.75" (22.22 cm); Width: 1.53" (3.89 cm); Depth: 15" (38.1 cm)
Number of Storage Slots	(9) per shelf	(9) per shelf	(9) per shelf	(9) per shelf
Power management dividers	20	20	30	30
Shipping Box Dimensions	48.5"H x 35"W x 32"D (123.19 x 88.9 x 81.28 cm)	48.5"H x 35"W x 32"D (123.19 x 88.9 x 81.28 cm)	48.5"H x 35"W x 32"D (123.19 x 88.9 x 81.28 cm)	48.5"H x 35"W x 32"D (123.19 x 88.9 x 81.28 cm)
Weight Capacity on Top Surface	150 lb. (68.2 kg), stationary	150 lb. (68.2 kg), stationary	150 lb. (68.2 kg), stationary	150 lb. (68.2 kg), stationary
Warranty	Carts: Lifetime; Electronics: 3 years	Carts: Lifetime; Electronics: 3 years	Carts: Lifetime; Electronics: 3 years	Carts: Lifetime; Electronics: 3 years

18- or 27-Device Cart with Intelligent Charging System Data Sheet

Dimensional Diagrams

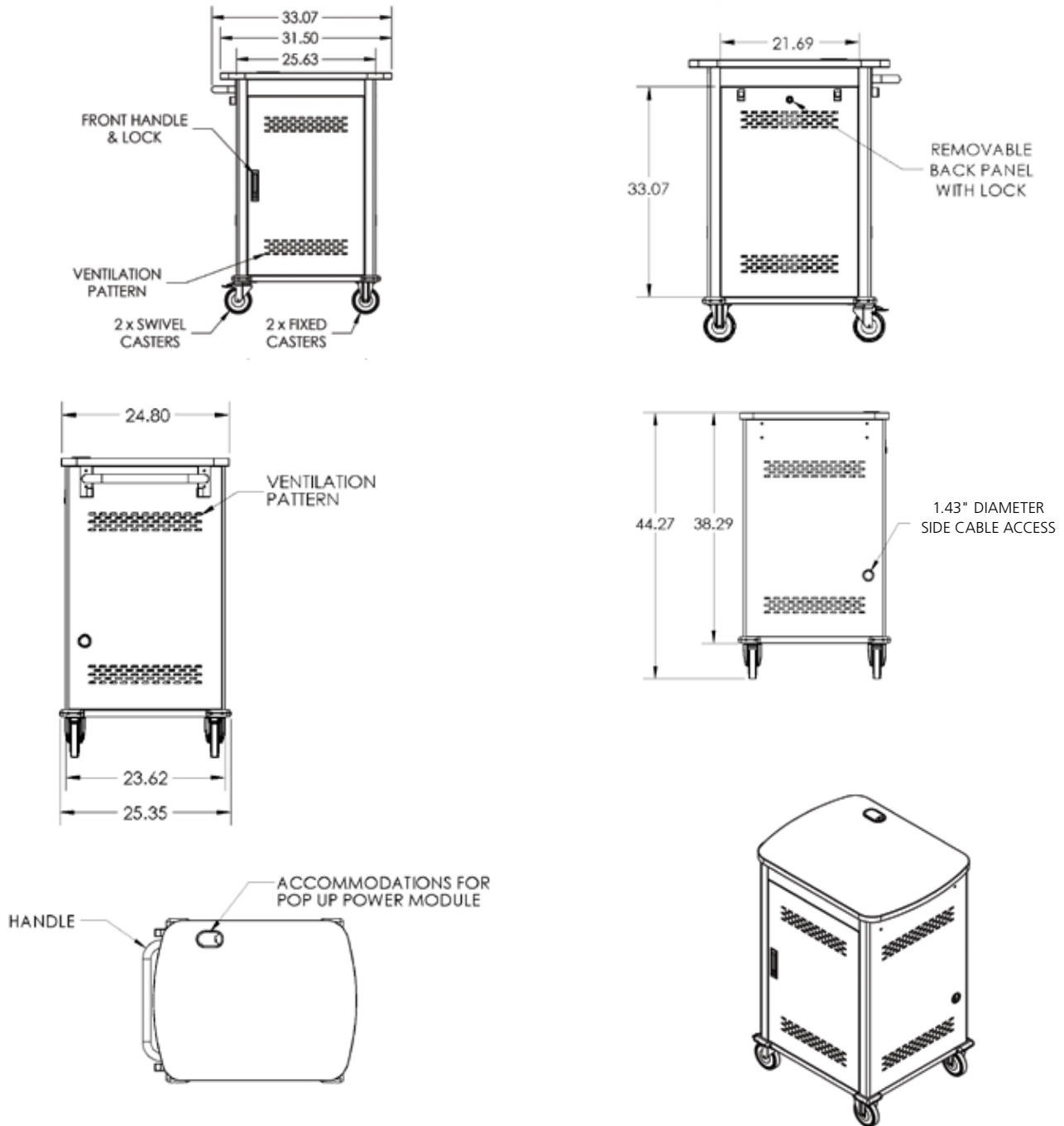

Disclaimer:

Black Box Network Services shall not be liable for damages of any kind, including, but not limited to, punitive, consequential or cost of cover damages, resulting from any errors in the production information or specifications set forth in this document and Black Box Network Services may revise this document at any time without notice.

© Copyright 2016. Black Box Corporation. All rights reserved. Black Box® and the Double Diamond logo are registered trademarks of BB Technologies, Inc. Any third-party trademarks appearing in this publication are acknowledged to be the property of their respective owners.